

# **HAKKO 484** DESOLDERING TOOL

## DESOLDERING TOOL

# Instruction Manual

Thank you for purchasing the HAKKO 484  
Desoldering Tool.

This Manual describes the use and maintenance of the  
HAKKO 484. Please read it before using the unit. After  
reading the manual, keep it in a safe place for future  
reference.

### Table of Contents

Accessories, Specifications .....	1
Part Names (Vacuum Pump) (Desoldering Gun) .....	2
Operation (Preparation- Assembly and Connection) (Desoldering) .....	3
(Post-operation Maintenance) (Troubleshooting Guide) .....	4
Maintenance (Cleaning the nozzle and Heating Core) .....	5
(Replacing the Filter) .....	6
(Clean the Pump) .....	7
Replacement Parts (Replacing the Heating Element) (Replacing the Heating Core) .....	8
Parts List .....	9
Wiring .....	10

## Accessories

Holder Parts .....	1
Cleaning Pin .....	1
(for $\phi 1.0\text{mm}$ <0.04in> Nozzle)	
Cleaning Pin .....	1
(for Heating Core)	
Cleaning Wrench .....	1

Filter Set .....	5
( Steel Wool Filter	)
( Ceramic Paper Filter S	
( Ceramic Paper Filter L	
Anti-seizure Lubricant .....	1
Silicone Grease .....	1

## Specifications

Name	HAKKO484
No.	484
Power Consumption	60W

### • Vacuum Pump

Part No.	484-2
Vacuum Generator	Double cylinder type
Vacuum Pressure (Max)	80kpa(600mmHg)(24 in Hg)
Flux Absorption	10 $\ell$ - 12 $\ell$ /min.
Motor Output	12W(4-pole)
Outer Dimensions (W×H×D)	135×75×180(mm) (5.3×3.0×7.1 in)
Weight	Approx.2.5kg(5.5lb)

\* Specifications are subject to change without notice.

### • Desoldering Gun

Part No.	484-1
Heating Element	30W,Ceramic
Temperature	370°C(698°F)
Insulation Resistance	100M $\Omega$
Filter Pipe	Pyrex glass (Heat Resistance)
Filter	2-stage(replaceable)
Nozzle Inside Diameter	$\phi 1.0\text{mm}$ [0.04in] (Standard)
Weight (w/o Cord, Hose)	Approx.230g (0.5lb)

# Part Names

## ● Vacuum Pump

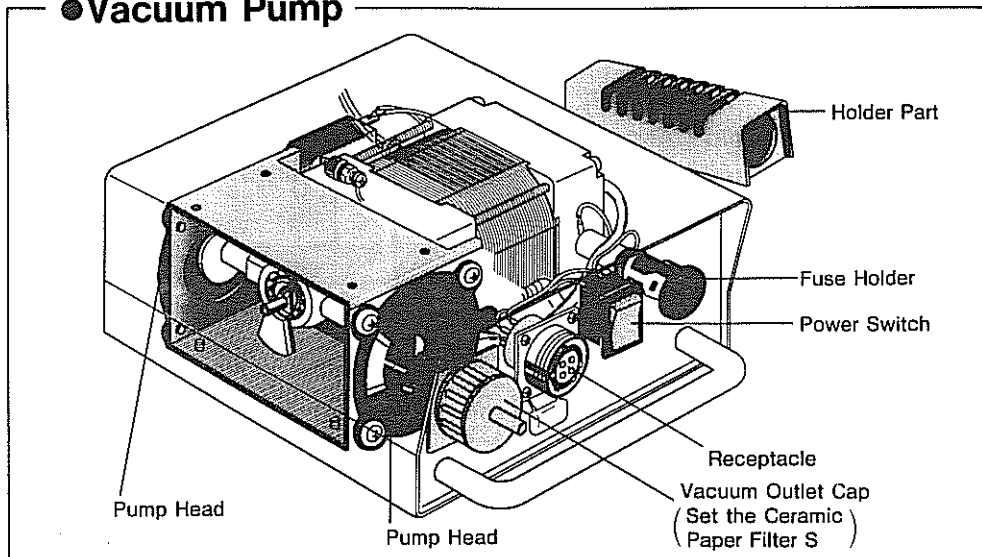

## ● Desoldering Gun

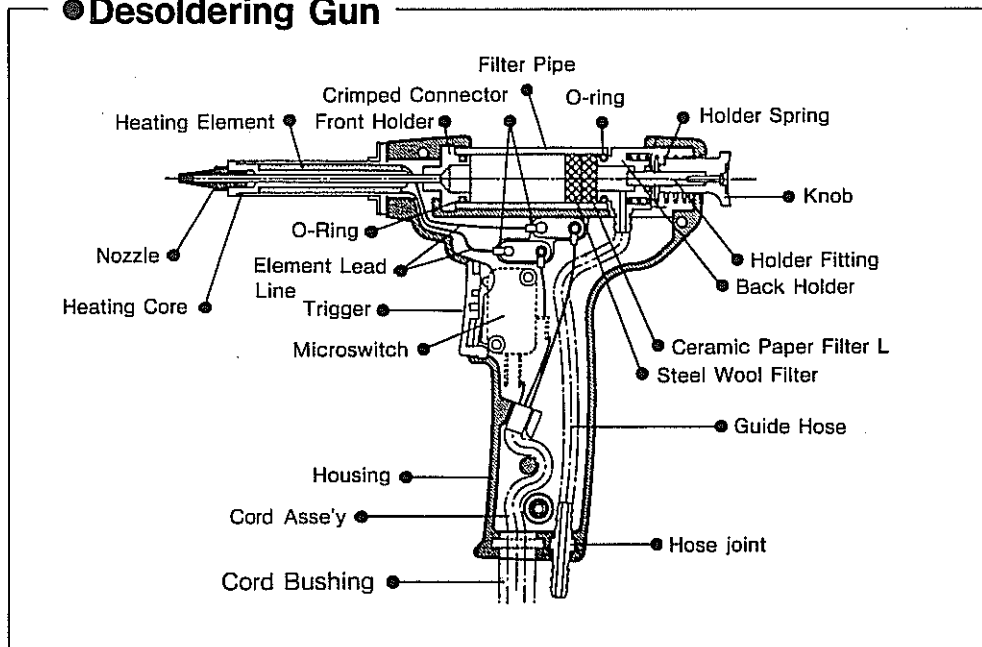

# Operation

## Preparation — Assembly and Connection

### 1. Assemble the Holder Part

Refer to Fig. 1.

### 2. Connections

- Connect the Cord Asse'y to the Receptacle (marked "IRON").
- Connect the Hose to the Vacuum Outlet Cap (marked "VACUUM")

### 3. Connect the Power Plug to the Power source

#### CAUTION:

For safety reasons, be sure to ground the unit. If the Power Cord is a two-wire cord, connect the supplied Grounding wire to the Grounding Terminal at the back of the unit and to a properly grounded plug.

### 4. Turn the Power Switch ON, confirm that the Power Lamp lights up

After turning the Power Switch to ON, wait 10 minutes before beginning desoldering operations.

## Desoldering

After turning the Power Switch to ON, wait 10 minutes before beginning desoldering operations.

### 1. Clean the Nozzle and Heating Core

- Clean out the hole of the Nozzle with the Cleaning Wrench, remove the Nozzle.
  - Clean the Heating Core with the Cleaning Pin, attach it.
- Refer to P.5 for cleaning the Nozzle and Heating Core.

### 2. Melt the solder

Apply the Nozzle to the soldered part and melt the solder.

Caution: Never allow the Nozzle to touch the board itself.

### 3. Absorb the solder

After confirming that the solder completely melted, absorb the solder by squeezing the trigger on the Gun.

#### ◆ Problems during Desoldering

If solder remains, resolder the component and repeat the desoldering process.

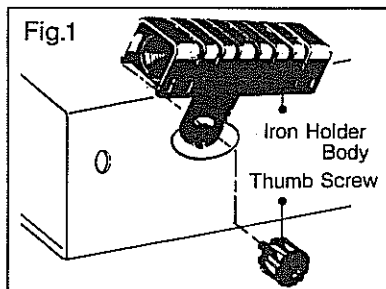

NOTE : The new Nozzle is closed by solder plating. After heating up, absorb the solder by squeezing the trigger on the Gun.

NOTE : Do not use the Gun before it has heated sufficiently, as use before this time may result in the Nozzle or the Heating Core becoming clogged with cold solder and flux.

## Post-operation Maintenance

### 1. Clean the Nozzle and Heating Core

Before turning the Power Switch off, clean the Nozzle and Heating Core. And loosen the Nozzle between uses to prevent the clogging or "freezing" of the Nozzle and Heating Core.

### 2. Turn the Power Switch off

## Troubleshooting Guide

### ● Power Lamp does not light up

- Is the Power Cord plugged in correctly ?
- Is the Fuse blown ?

### ● Pump does not operate.

- Is the Cord Assembly properly connected ?
- Is the Nozzle or Heating Core clogged ? <Refer to P5>

### ● Solder is not being absorbed

- Does the Pump operate ?
- Is the Filter Pipe full of solder ? (Refer to P6)
- Is the Ceramic Paper Filter hardened ? (Refer to P6)
- Is the Hose properly connected ?
- Is the Filter Pipe attached to the Front Holder and Back Holder Assembly ?

### ● The Nozzle does not heat up

- Is the Desoldering Gun Cord Assembly properly connected ?
- Is the Heating Element damaged ? <Refer to P8>
- Is the Nozzle eroded ? <Refer to P5>

Caution: When repairs are needed, please send both the Desoldering Gun and the Station to your sales agent.

# Maintenance

## **⚠ CAUTION:**

Except when cleaning the Nozzle and Heating Core, always turn the Power Switch off and disconnect the Power Plug before performing any maintenance procedure.

Properly maintained, the HAKKO 484 Desoldering Gun should provide years of good service. Efficient desoldering depends upon the temperature, and the quality and quantity of the solder and flux. Perform the following service procedures as dictated by the conditions of the Gun's usage.

### **Cleaning the Nozzle and Heating Core**

## **⚠ CAUTION:**

The Desoldering Gun will be extremely hot. During maintenance, please wear gloves and work carefully.

Replace the following Nozzle :

- The clogging or "Freezing" Nozzle
- The oxidation is thick on threads of Nozzle
- Diameter of hole is widened through erosion

### **1. Turn the Power Switch ON**

Let the Nozzle heat up for 10 minutes.

### **2. Remove the Nozzle**

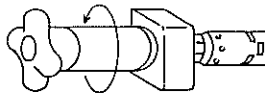

Turn the Nozzle counterclockwise with Cleaning Wrench and remove it.

### **3. Clean the Heating Core**

Scrape away all oxidation from the hole in the Heating Core until the Cleaning Pin passes cleanly through the hole.

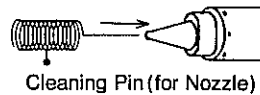

Cleaning Pin (for Nozzle)

### **4. Apply anti-seizure lubricant**

- Apply anti-seizure lubricant on the threads of Nozzle and Heating Core.
- Attach the Nozzle with the Cleaning Wrench

### **5. Inspect and clean the Nozzle**

The Cleaning Pin passes completely through the hole.

Cleaning Pin (for Heating Core)

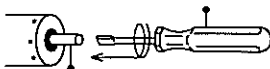

Heating Core

Caution: Apply anti-seizure lubricant the threads of Nozzle and Heating Core to prevent it from "freezing" (seizing) , once a week and replacing the Nozzle.

## Replacing the Filter

### ● Replace the Filters in the Filter Pipe ●

Should the suction power become reduced due to full of the solder in the Filter Pipe, clean or replace the Steel Wool Filter and Ceramic Paper Filter L.

#### 1. Remove the Filter Pipe

- Pull the knob (marked "PULL") backward, secure it by turning 90 degree on either way of left or right.
- Pull the Filter Pipe backward approx. 5.0mm (0.19in) , remove it.

#### 2. Clean the Filter Pipe

- Remove the accumulated solder from the Filter Pipe.
- If the Steel Wool Filter is hardened with solder, replace it.
- If the Ceramic Paper Filter is stiff with flux and solder, replace it.

Caution: Be sure to insert the filters so that the Ceramic Paper Filter L (thickness of 6.0mm <0.24in>) is at the front of it.

Caution: Do not operate the Pump without the filters.

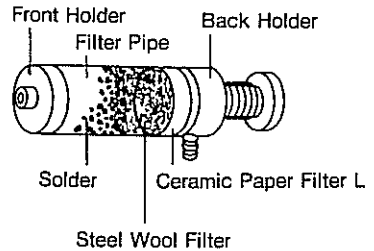

### ● Replace the Filter in the Filter Case ●

If the Ceramic Paper Filter S is stiff with flux, replace it.

#### 1. Disassemble the Vacuum Outlet Cap

- Remove the Hose.
- Unscrew the Vacuum Outlet Cap

#### 2. Replace the Ceramic Paper Filter S

#### 3. Reassemble

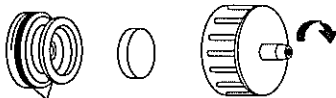

Secure the Vacuum Outlet Cap

Apply Silicone Grease and securely tighten the Vacuum Outlet Cap to prevent air leakage

Caution: Set the Ceramic Paper Filter S for Filter Case (Station). Using the Ceramic Paper Filter L in the Filter Case may cause to break or the power to drop.

Caution: Be aware that Silicone Grease might damage the solder joints on P.W. Board.

## Clean the Pump

### 1. Remove the Pump

- Remove the Cover.
- Unscrew the 4 screws securing the Pump Head.
- Remove the inside Hose.
- Remove the Pump from each side of the Pump.

### 2. Clean the Pump Head

- Remove the Valve Plate and Fixing Plate.
- Remove any flux adhering to the Plates.

**Caution:**

If the Fixing Plate is difficult to remove, apply hot air to it to warm it up. Never use excessive force to remove the plate as it is easy to bend, and a bent Plate will allow air to leak out and reduce solder vacuuming efficiency.

**Caution:**

Clean the Plates only with alcohol or thinner

- If the Valve Plate is bent or stiff, replace it.
- If the Exhaust Filter is dirty, replace it.

### 3. Assemble the Pump Head

- Reassemble the Valve Plate and Fixing Plate.
- Apply the Silicone Grease to the surfaces of the Valve Plate and Diaphragm before reassembling them.

**Caution:**

When assembling the Pump, be sure to check for air leaks.

**Caution:**

Be aware that Silicone Grease might damage the solder joints on the P.W.Board.

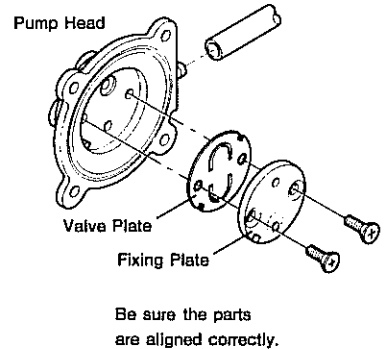
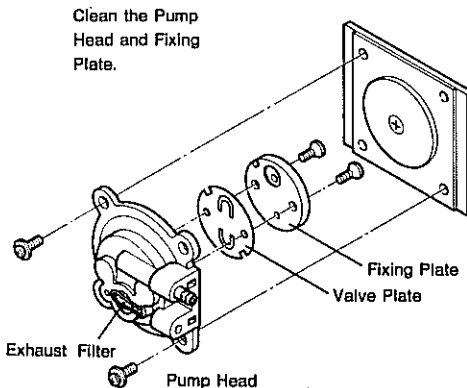



# Replacement Parts

## Replacing the Heating Element

### 1. Remove the Filter Pipe

Refer to P.6

### 2. Separate the Housing

- Unscrew the 4 screws securing the heating Core.
- Unscrew the 3 screws securing the Housing.
- Separate the Housing, then turn the Nozzle at the left side.

### 3. Replace the Heating Element

- Remove the Heating Core.
- Unscrew the 2 screws securing the Heating Element.
- Insert a new Heating Element.

Caution: Connect the short Heating Element Lead to the Terminal near the Microswitch.

### 4. Reassemble

## Replacing the Heating Core

### 1. Remove the Nozzle

### 2. Remove the Heating Core

Unscrew the 4 screws securing the Heating Core, remove it.

### 3. Reassemble

Replace a new Heating Core, then insert this thin pipe into the hole of the Front Holder.

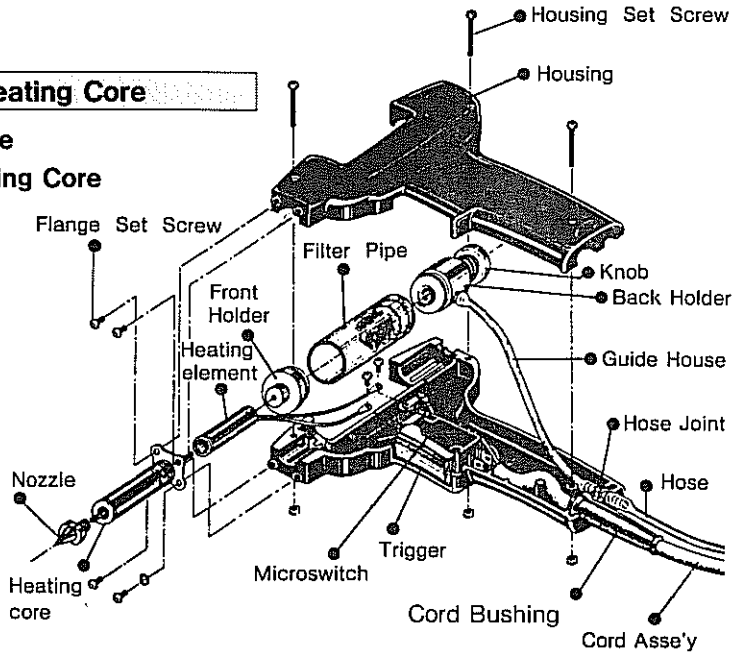

# Parts List

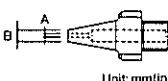
Part No.	Part Name	Specification															
481-T-0.8	Nozzle $\phi$ 0.8mm(0.03in)	 <table border="1" style="margin-left: auto; margin-right: auto;"> <thead> <tr> <th></th> <th><math>\phi</math>0.8</th> <th><math>\phi</math>1.0</th> <th><math>\phi</math>1.3</th> <th><math>\phi</math>1.6</th> </tr> </thead> <tbody> <tr> <td>A'</td> <td>0.8 (0.03)</td> <td>1.0 (0.04)</td> <td>1.3 (0.05)</td> <td>1.6 (0.06)</td> </tr> <tr> <td>B</td> <td>2.5 (0.09)</td> <td>2.5 (0.09)</td> <td>2.5 (0.09)</td> <td>3.0 (0.1)</td> </tr> </tbody> </table> <p style="text-align: center;">Unit:mm(in)</p>		$\phi$ 0.8	$\phi$ 1.0	$\phi$ 1.3	$\phi$ 1.6	A'	0.8 (0.03)	1.0 (0.04)	1.3 (0.05)	1.6 (0.06)	B	2.5 (0.09)	2.5 (0.09)	2.5 (0.09)	3.0 (0.1)
	$\phi$ 0.8		$\phi$ 1.0	$\phi$ 1.3	$\phi$ 1.6												
A'	0.8 (0.03)		1.0 (0.04)	1.3 (0.05)	1.6 (0.06)												
B	2.5 (0.09)		2.5 (0.09)	2.5 (0.09)	3.0 (0.1)												
481-T-1.0	Nozzle $\phi$ 1.0mm(0.04in)																
481-T-1.3	Nozzle $\phi$ 1.3mm(0.05in)																
481-T-1.6	Nozzle $\phi$ 1.6mm(0.06in)																

Part No.	Part Name	Specification
B1085	Cleaning Pin	for Heating Core
B1086	Cleaning Pin	for $\phi$ 0.8mm(0.03in) Nozzle
B1087	Cleaning Pin	for $\phi$ 1.0mm(0.04in) Nozzle
B1088	Cleaning Pin	for $\phi$ 1.3mm(0.05in) Nozzle
B1089	Cleaning Pin	for $\phi$ 1.6mm(0.06in) Nozzle
481-020	Cleaning Wrench	
B1302	Cleaning Drill	for $\phi$ 0.8mm(0.03in) Nozzle
B1303	Cleaning Drill	for $\phi$ 1.0mm(0.04in) Nozzle
B1304	Cleaning Drill	for $\phi$ 1.3mm(0.05in) Nozzle
B1305	Cleaning Drill	for $\phi$ 1.6mm(0.06in) Nozzle

Part No.	Part Name	Specification
A1009	Ceramic Paper Filter(S)	for Filter Case 10pcs.
A1033	Ceramic Paper Filter(L)	for Filter Pipe 10pcs.
481-021	Filter Set	Steel Wool and Ceramic Paper Filter(S/L)
481-002	Filter Pipe	w/Steel Wool and Ceramic Paper Filter L
481-H	Heating Element	30W Ceramic Heater
481-012	Heating Core	
481-101	Front Holder	with O-Ring(P12)
481-102	Back Holder	Assembly, with O-Ring(P12)
A1012	O-Ring(P12)	5pcs.
481-026	Anti Seizure	
A1028	Silicone Grease	
B1050	Pump Head	
A1013	Diaphragm	set of 2
A1014	Valve Plate	Set of 2
B1056	Fixing Plate	
B1059	Exhaust Filter	Set of 2
B1313	Filter Retaining Pin	
481-016	Housing	
481-013	Hose	1.5m
484-023	Cord Ass'y	4 Core Cord with Connecting Plug
609-022	Holder Part	

# Wiring

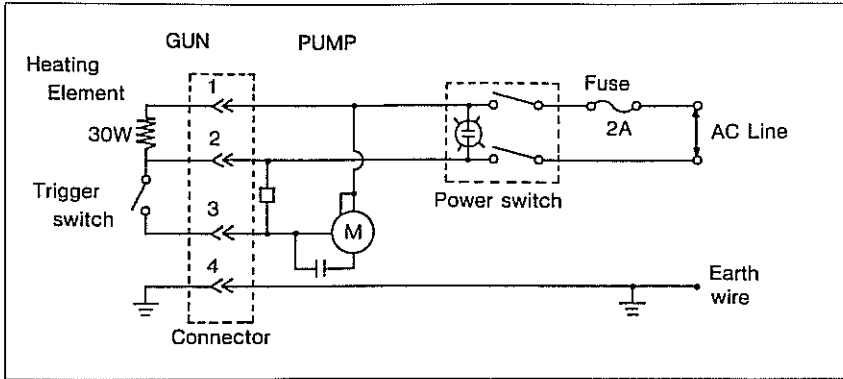

中國RoHS: 產品中有毒有害物質或元素的名稱及含量

部件名稱	有毒有害物質或元素					
	鉛(Pb)	汞(Hg)	鎘(Cd)	六價鉻(Cr(VI))	多溴聯苯(PBB)	多溴二苯醚(PBDE)
護艙	×	○	○	○	○	○
軟管連接器	×	○	○	○	○	○
馬達	×	○	○	○	○	○
終端板	×	○	○	○	○	○
泵組件	×	○	○	○	○	○
吸錫槍部	×	○	○	○	○	○
電路板	×	○	○	○	○	○
保險絲套	×	○	○	○	○	○
清潔鑽	×	○	○	○	○	○
插頭	×	○	○	○	○	○

○ : 表示該有毒有害物質在該部件所有均質材料中的含量均在SJ/T 11363-2006標準規定的限量要求以下。  
 × : 表示該有毒有害物質至少在該部件的某一均質材料中的含量超出SJ/T 11363-2006標準規定的限量要求。



**HAKKO CORPORATION**

**HEAD OFFICE**

TEL:+81-6-6561-3225 FAX:+81-6-6561-8466  
<http://www.hakko.com> E-mail:sales@hakko.com

**OVERSEAS AFFILIATES**

**U.S.A.: AMERICAN HAKKO PRODUCTS, INC.**

TEL: (661) 294-0090 FAX: (661) 294-0096

Toll Free (800)88-HAKKO

<http://www.hakkousa.com>

**HONG KONG: HAKKO DEVELOPMENT CO., LTD.**

TEL: 2811-5588 FAX: 2590-0217

<http://www.hakko.com.hk>

E-mail:info@hakko.com.hk

**SINGAPORE: HAKKO PRODUCTS PTE., LTD.**

TEL: 6748-2277 FAX: 6744-0033

<http://www.hakko.com.sg>

E-mail:sales@hakko.com.sg

**Please access to the following address for the other Sales affiliates.**

**<http://www.hakko.com>**